

BALDOR • RELIANCE

Customer information packet

M3460

.5HP, 3420RPM, 3PH, 60HZ, 48, 3410M, TEFC, F1, N

Class - None

Division - Not Applicable

Copyright © All product information within this document is subject to ABB Motors and Mechanical Inc. copyright © protection, unless otherwise noted.

11/28/2024 10:46:35 PM

Specifications

Enclosure	TEFC
Frame	48
Frame Material	Steel
Frequency	60.00 Hz
Haz Area Class and Group	None
Haz Area Division	Not Applicable
Motor Letter Type	Three Phase
Output @ Frequency	.500 HP @ 60 HZ
Phase	3
Synchronous Speed @ Frequency	3600 RPM @ 60 HZ
Voltage @ Frequency	230.0 V @ 60 HZ 460.0 V @ 60 HZ
Agency Approvals	CSA UR
Ambient Temperature	40 °C
Auxillary Box	No Auxillary Box
Auxillary Box Lead Termination	None
Base Indicator	Rigid
Bearing Grease Type	Polyrex EM (-20F +300F)
Blower	None
Current @ Voltage	.800 A @ 460.0 V 1.540 A @ 208.0 V 1.600 A @ 230.0 V
Design Code	B
Drip Cover	No Drip Cover
Duty Rating	CONT
Efficiency @ 100% Load	72.0 %
Electrically Isolated Bearing	Not Electrically Isolated
Feedback Device	NO FEEDBACK
Front Shaft Indicator	None
Heater Indicator	No Heater
High Voltage Full Load Amps	0.8 a

Part detail

Revision	B
Type	AC
Mech. spec.	34A051
Base	
Status	PRD/A
Elec. spec.	34WGR708
Layout	34LYA051
Eff. date	10-25-2024
CD Diagram	CD0005
Poles	02
Leads	9#18
Proprietary	False
Created date	02-08-2021

Insulation Class	B
Inverter Code	Not Inverter
KVA Code	J
Lifting Lugs	No Lifting Lugs
Locked Bearing Indicator	No Locked Bearing
Motor Lead Quantity/Wire Size	9 @ 18 AWG
Motor Lead Termination	Flying Leads
Motor Standards	NEMA
Motor Type	3410M
Mounting Arrangement	F1
Number of Poles	2
Overall Length	10.73 IN
Power Factor	80
Product Family	General Purpose
Pulley End Bearing Type	Ball
Pulley Face Code	Standard
Pulley Shaft Indicator	Standard
Rodent Screen	None
Service Factor	1.25
Shaft Diameter	0.500 IN
Shaft Ground Indicator	No Shaft Grounding
Shaft Rotation	Reversible
Shaft Slinger Indicator	No Slinger
Speed	3420 rpm
Speed Code	Single Speed
Starting Method	Direct on line
Thermal Device - Bearing	None
Thermal Device - Winding	None
Vibration Sensor Indicator	No Vibration Sensor
Winding Thermal 1	None
Winding Thermal 2	None

Nameplate

NP1256L									
CAT.NO.	M3460								
SPEC.	34A051R708								
HP	.5								
VOLTS	230/460								
AMP	1.6/.8								
RPM	3420								
FRAME	48		HZ	60		PH	3		
SER.F.	1.25	CODE	J	DES	B	CLASS	B		
NEMA-NOM-EFF	72	PF	80						
RATING	40C AMB-CONT								
CC									
DE	6203	ODE	6203						
ENCL	TEFC	SN							
	SFA 1.9/0.95								

Accessories

Part number	Description	Multiplier
34-3900T	C-FACE KIT	A8

AC Induction Motor Performance Data

Record # 85597

Preliminary Data Sheet

Winding: 34WGR708-R001		Type: 3410M	Enclosure: TEFC	
Nameplate Data			460 V, 60 Hz: High Voltage Connection	
Rated Output (HP)	.5	Full Load Torque	0.77 LB-FT	
Volts	230/460	Start Configuration	direct on line	
Full Load Amps	1.6/0.8	Breakdown Torque	2.65 LB-FT	
R.P.M.	3420	Pull-up Torque	1.68 LB-FT	
Hz	60 Phase	3	Locked-rotor Torque	1.89 LB-FT
NEMA Design Code	B KVA Code	J	Starting Current	4.72 A
Service Factor (S.F.)	1.25	No-load Current	0.59 A	
NEMA Nom. Eff.	72 Power Factor	80	Line-line Res. @ 25°C	50.7 Ω
Rating - Duty	40C AMB-CONT	Temp. Rise @ Rated Load	53°C	
S.F. Amps	1.9/.0.95	Temp. Rise @ S.F. Load	70°C	
		Locked-rotor Power Factor	76.8	
		Rotor inertia	0.0093 lb-ft ²	

Load Characteristics 460 V, 60 Hz, 0.5 HP

% of Rated Load	25	50	75	100	125	150	S.F.
Power Factor	41	57	71	80	87	91	87
Efficiency	52.3	65.9	71.6	72.6	73.4	71.8	73.4
Speed	3550	3511	3469	3420	3365	3300	3365
Line amperes	0.61	0.65	0.72	0.8	0.93	1.08	0.93

ABB Motors and Mechanical Inc.

WINDING # 34WGR708

Typical performance - not guaranteed values.

0.5 HP 3 PH 60 HZ 3420 RPM 460 V 3410M

TORQUES (LB-FT): PO=2.65 PU=1.68 LR=1.89 LRA=4.72

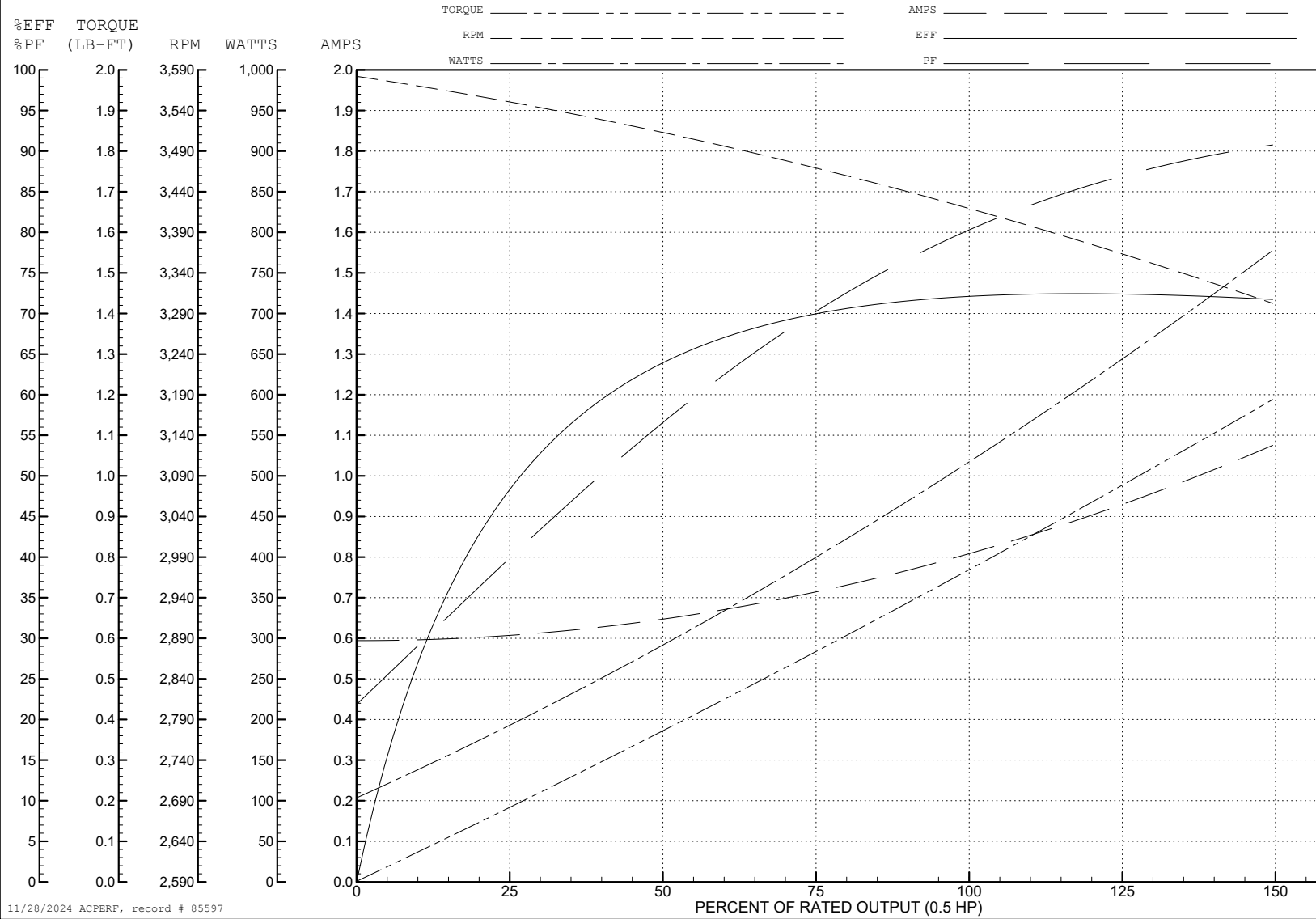

11/28/2024 ACPERF, record # 85597

34LYA051

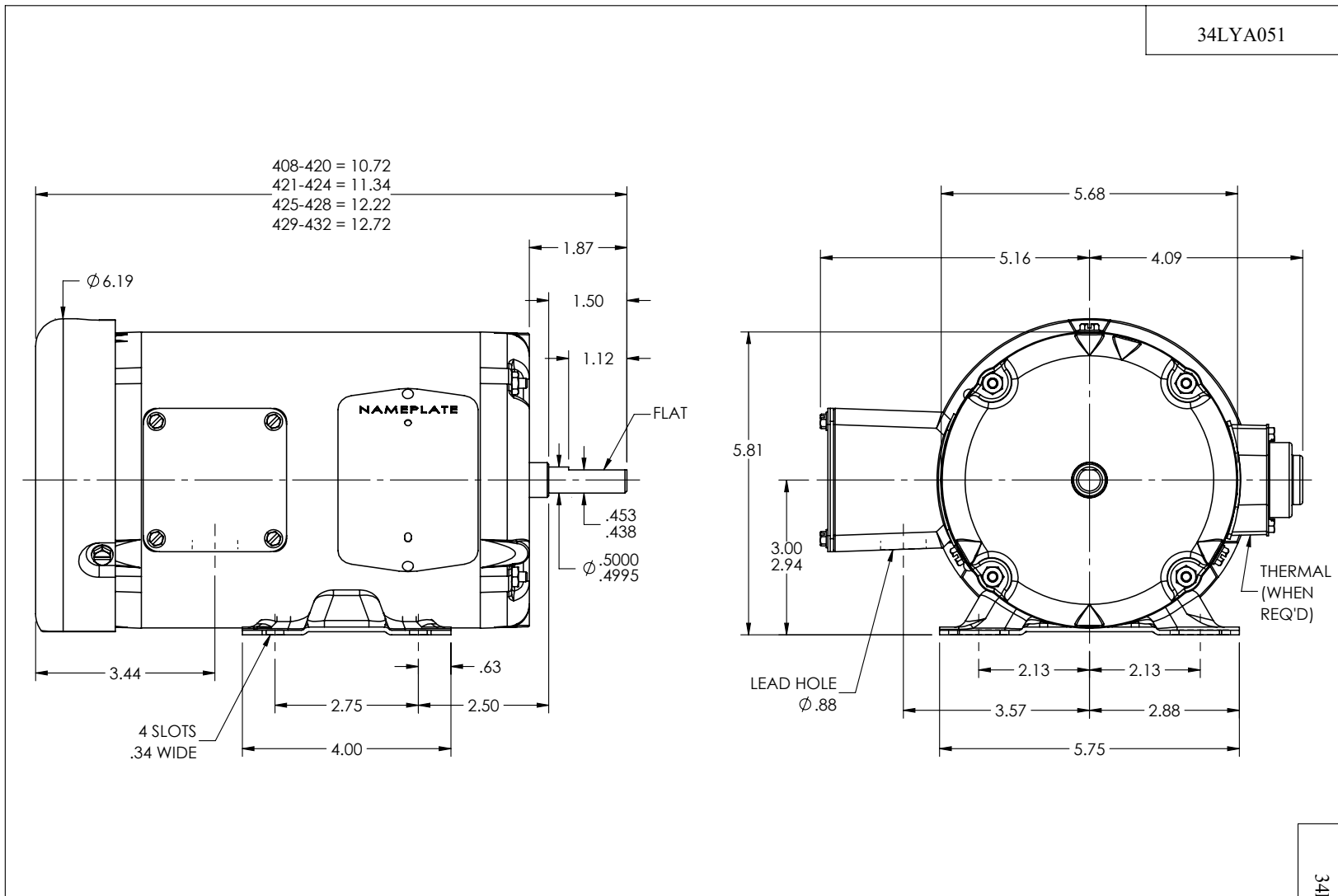

CUSTOMER IS RESPONSIBLE FOR DETERMINING THAT THE PRODUCT WILL PERFORM SUITABLY IN THE INTENDED APPLICATION

REV. DESC: UPDATE DIMENSION GRAPHICS			
REV: P	VERSION: 07	REVISED: 03:05:58 11/26/2024	TDR: 000001245356
34LYA051		MODEL NO. 34LYA051	REF: -
		BY: ENJEFD0	

BALDOR - RELIANCE®

STD HORZ 34M NEMA 48 TEFC

34LYA051

CD0005



LOW VOLTAGE
(2Y)



LINE

HIGH VOLTAGE
(1Y)

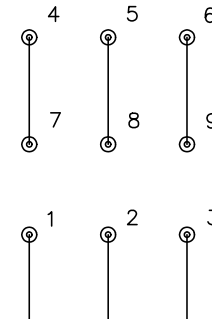

LINE

NOTES:

1. INTERCHANGE ANY TWO LINE LEADS TO REVERSE ROTATION.
2. OPTIONAL THERMOSTATS ARE PROVIDED WHEN SPECIFIED.
3. ACTUAL NUMBER OF INTERNAL PARALLEL CIRCUITS MAY BE A MULTIPLE OF THOSE SHOWN ABOVE.
4. LEAD COLORS ARE OPTIONAL. LEADS MUST ALWAYS BE NUMBERED AS SHOWN.

CD0005

REV. DESC: REVISE TO SHOW OPTIONAL COLORS			
REV. LTR: E	BY: JLP	REVISED: 01/19/99 10:15	TDR: 0171435
S00000		FILE: AAA00005140	MDL: -
		MTL: -	

BALDOR ELECTRIC Co.

3PH, DV, 9 LEADS