



PERFORMANCE DATA SHEET

Meets or exceeds MEPS, as described by the US DOE in docket 10CFR431 and NRCan's Amendment 14

Catalogue #: **MQS-6324NVB14**

HP	kW	Voltage	S.F. @ 60Hz	EFF.	P.F.	Frame	Design	L.R. Amps
0,25	0,19	230 / 460	1,15	75,0%	0,590	63	B	6

60 Hz								Code	F.L. RPM
FLA									
208	230	416	460	480	575	600		K	1735
/	1,06	/	0,53	/	/	/			

50 Hz								Code	F.L. RPM
FLA			S.F. @ 50Hz	Efficiency	Power Factor				
190	380	415				1,00	74,0%	0,61	
1,3	0,63	/							

Wgt. Lbs	PH	Duty	Insul. Class	Amb.	Elevation	Temp. Rise° C
17,6	3	Cont.	F	40°C	1000M (3300 Ft)	40

% Efficiency		% Power Factor		Torque		Winding Resist. Ω	Safe Cold Start (Secs)
Full Load:	75,0%	Full Load:	0,59	Full Load Ft/Lbs	0,8		
3/4 Load:	72,0%	3/4 Load:	0,50	Locked Rotor %	210		
1/2 Load:	67,5%	1/2 Load:	0,39	Break Down %	320		

Rotor Inertia Wk2 Lb-Ft2	Max Load Inertia Wk2 Lb-Ft2	Shaft Material	Frame Material	DE Bracket Type	ODE Bracket Type	Enclosure	NEMA Rating	Lead Wire Size
/	/	Stainless Steel 304				TENV	IP66	/

Ball Bearings		Grease	Mount Type	Orientation	Paint	Sound Pressure @ 3FT	Sound Power
DE	ODE						
6202	6202	Sealed Bearings	Rigid	Horizontal	-	/	/

Inverter Duty. Motor meets MG1 parts 31.4.4.2	Constant Torque Range	Variable Torque Range	Constant HP RPM
		10:1	20:1

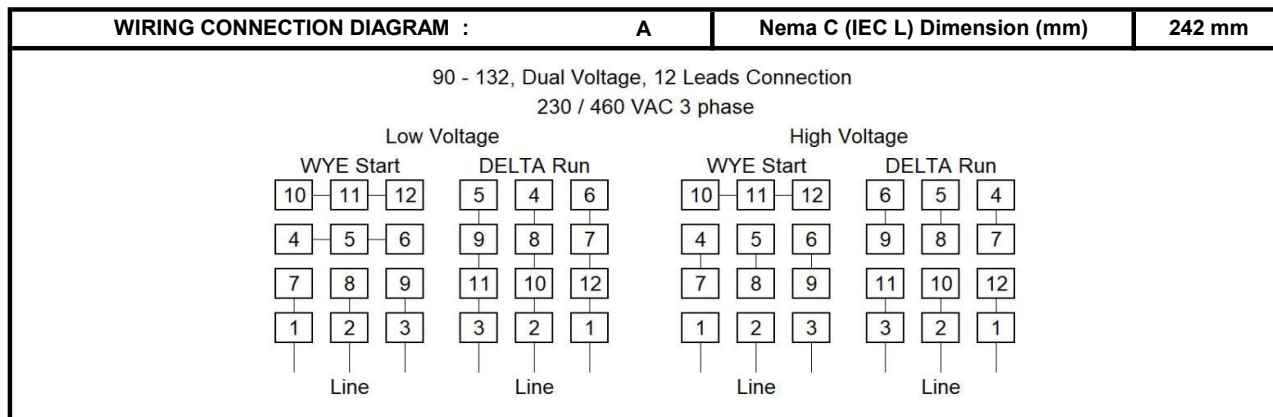

Date: 2023-12-21
 Customer: _____
 Contact: _____
 Submittee: J.C. Lavallée

Catalogue #: **MQS-6324NVB14**

Meets or exceeds MEPS, as described by the US DOE in docket 10CFR431 and NRCan's Amendment 14

HP	VAC	RPM	Enclosure	Frame	Frequency	Design	Poles	LR Code Letter	Insulation Class	Temp. Rise °C
0,25	460	1735	TENV	63	60	B	4	K	F	40
	0Hz	6Hz	15Hz	30Hz	45Hz	60Hz	75Hz	90Hz	105Hz	120Hz
Amps	0,53	0,53	0,53	0,53	0,53	0,53	0,53	0,53	0,53	0,53
RPM	0	173,5	433,75	867,5	1301,25	1735	2168,75	2602,5	3036,25	3470
Torq ft.lb	0,61	0,61	0,76	0,76	0,76	0,76	0,61	0,50	0,43	0,38
Peak Tq ft.lb	0,98	1,97	1,97	1,97	1,97	1,97	1,57	1,31	1,12	0,98
HP	0	0,0	0,1	0,1	0,2	0,3	0,3	0,3	0,3	0,3
	Locked Rotor	Pull-Up	Breakdown	Rated Load	Idle	Duty	S. F.	Ambient	Elevation	dBa @ 1M
Speed (RPM)	0,0	756	1440	1735	1800	Cont.	1,15	40°C	3,300 ft	/
Current (Amps)	6,0	5,1	3,6	0,5	0,4	VFD Rating: Meets MG1 parts 31.4.4.2				
Torque (ft-lbs)	1,6	1,4	2,4	0,8	0,0	C.T.	10:1	V.T.	20:1	

Motor Speed Data

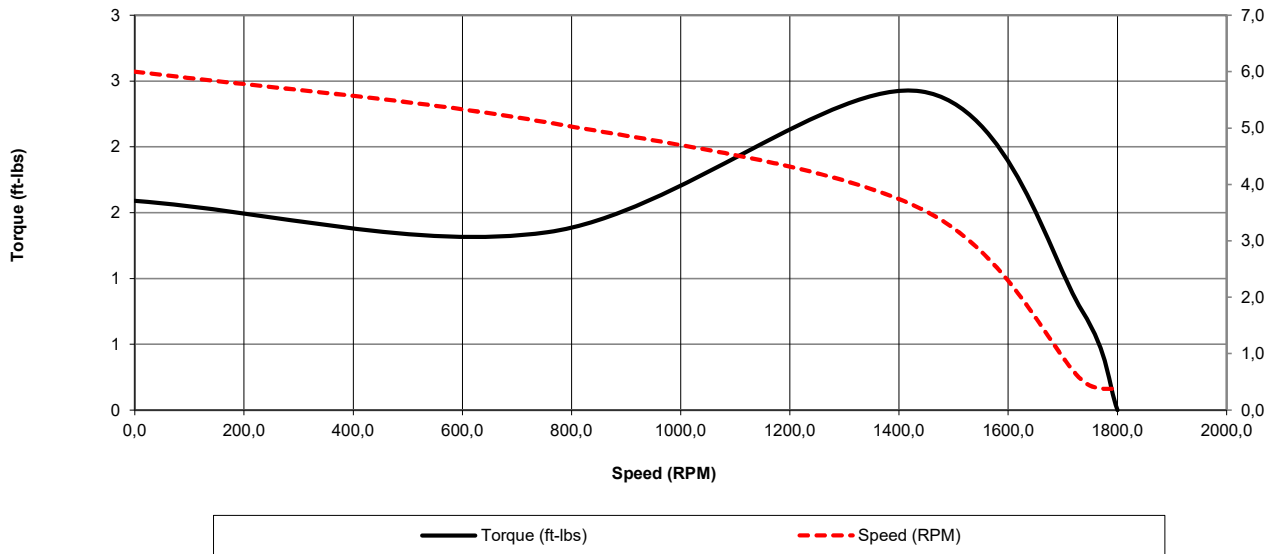

Motor Torque Capability vs RPM

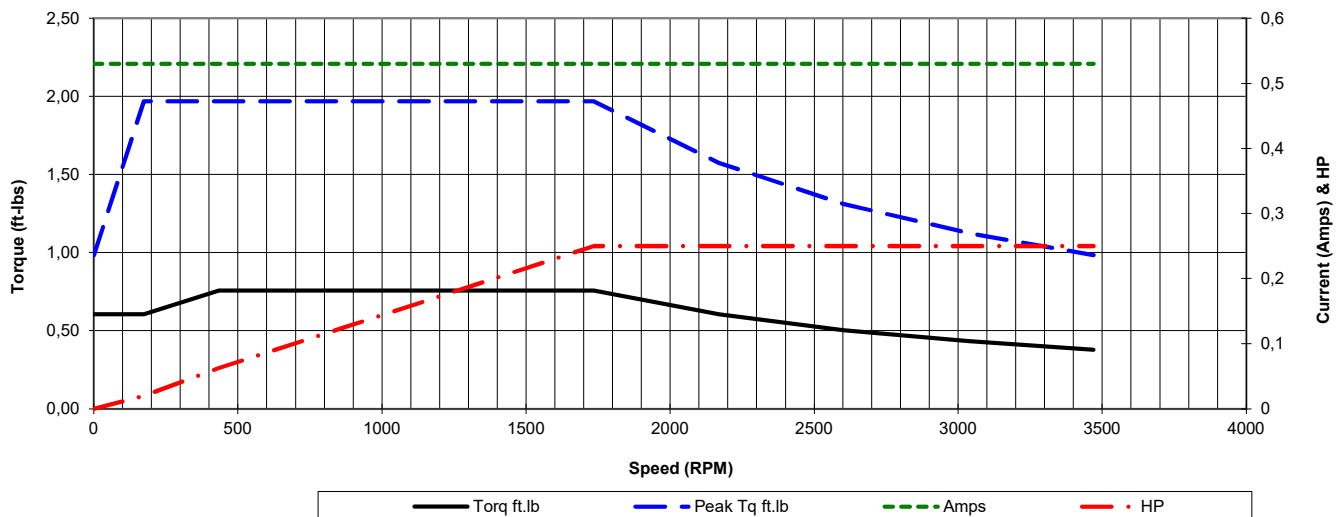

Date: 2023-12-21
 Customer: _____
 Contact: _____
 Submittee: J.C. Lavallée

Catalogue #: **MQS-6324NVB14**

Meets or exceeds MEPS, as described by the US DOE in docket 10CFR431 and NRCan's Amendment 14

HP	VAC	RPM	Enclosure	Frame	Frequency	Design	Poles	LR Code Letter	Insulation Class	Temp. Rise °C
0,25	460	1735	TENV	63	60	B	4	K	F	40

Load %	0%	25%	50%	75%	100%	125%	150%
Amps	0,38	0,40	0,43	0,47	0,53	0,66	0,80
Torq ft/lbs	0	0,18	0,37	0,56	0,76	0,95	1,16
RPM	0	1783,75	1767,5	1751,25	1735	1718,75	1702,5
Eff	0	59,20	67,50	71,98	75,00	73,39	71,29
PF	0	25,4	38,586	49,855	59,0	60,2	62,0

	Locked Rotor	Pull-Up	Breakdown	Rated Load	Idle	Duty	S. F.	Ambient	Elevation	dBA @ 1M
Speed (RPM)	0	756	1440	1735	1800	Cont.	1,15	40°C	3,300 ft	/
Current (Amps)	6	5,1	3,6	0,53	0,3763	VFD Rating: Meets MG1 parts 31.4.4.2				
Torque (ft-lbs)	1,59	1,35	2,42	0,76	0,0	C.T.	10:1	V.T.	20:1	

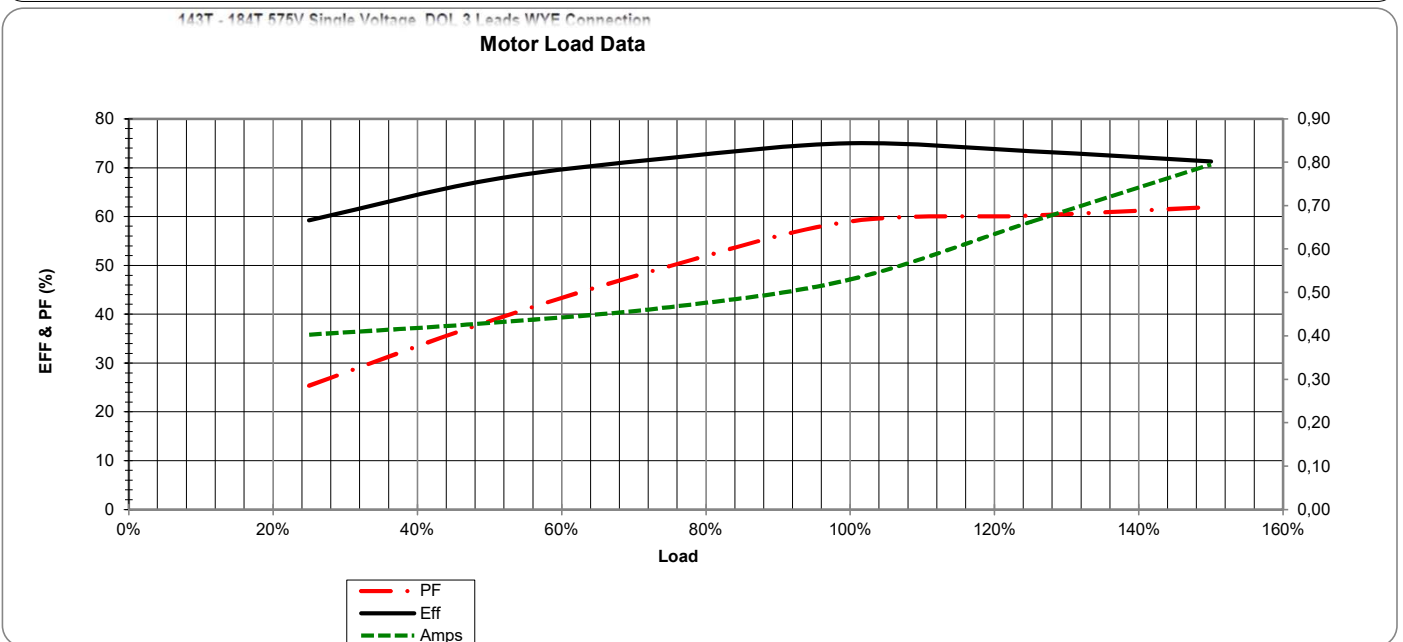
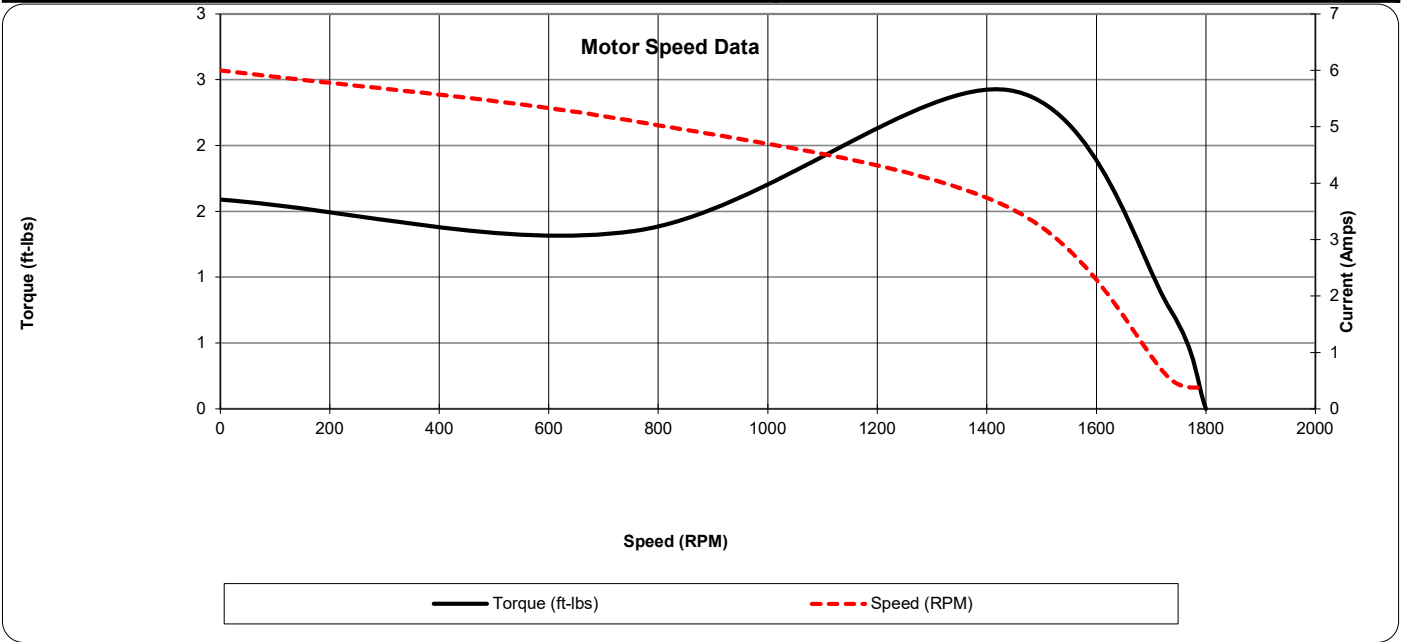

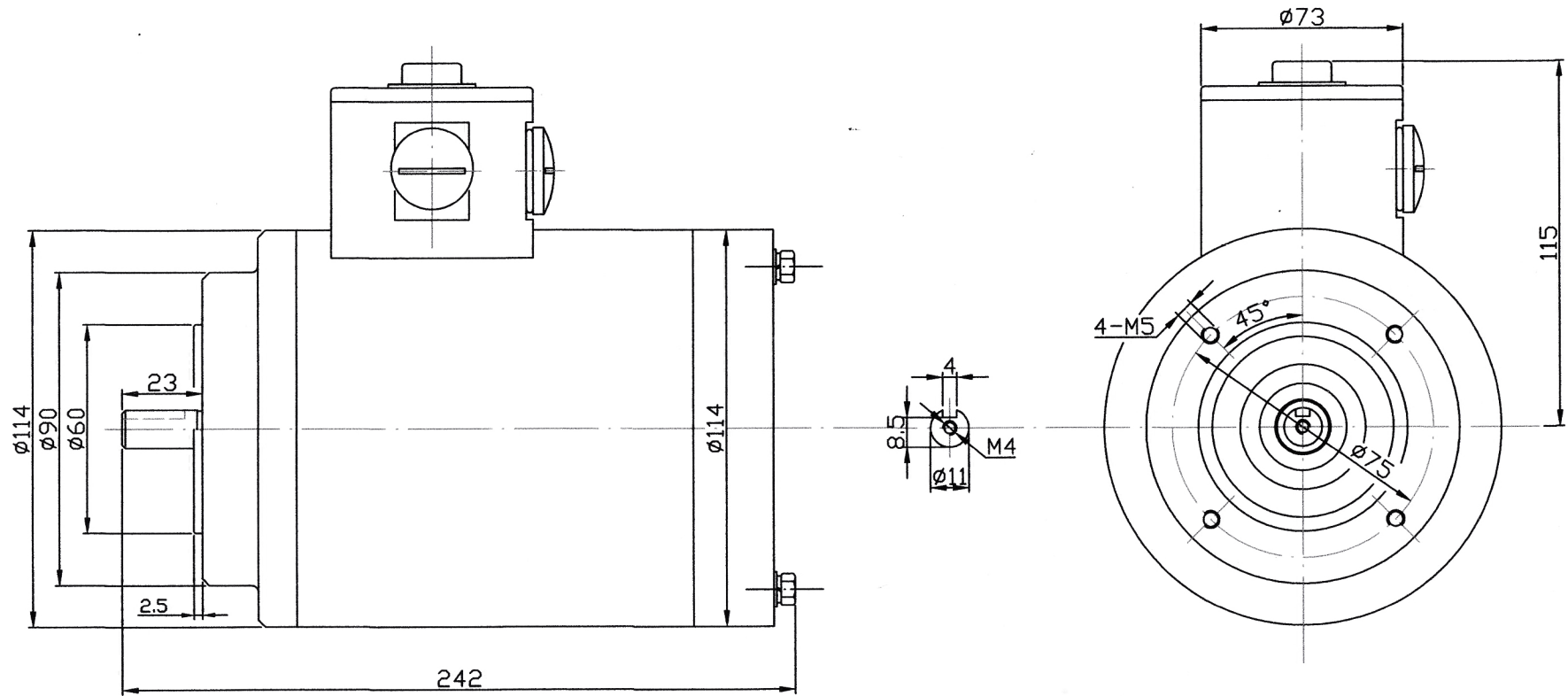

Version: 2WT1	Revised: June 2024	HP	RPM	FRAME	ENCLOSURE	MPS/MS-6324NVB14
Customer is responsible in determining that MEP product will fit/perform suitably in the intended application		1/4	1800	63	TENV	

PREMIUM DESIGN B NEMA 12-12

304 GRADE STAINLESS STEEL TENV TOTALLY ENCLOSED
NON-VENTILATED & TEFC TOTALLY ENCLOSED FAN COOLED

MaxMotion

Applications:

A versatile motor design that can be base mounted or flange mounted to equipment operating in wet and severe conditions, and where wash down duty and corrosive elements are found such as in the food processing, bottling, dairy, pharmaceutical, and chemical processing industries.



Features:

Design - IEC Design N with NEMA Design B torque Curves

Agency Listings and Standard - NEMA, IEEE, CSA, CSAus, CE, NRCan

Service Factor - 1.15 @ 60Hz and 1.0 @ 50hZ without derating power

Electrical Supply - At 60Hz : 230/460v Dual Rated & Plated for 50Hz : 190/380-415v

Windings - Highest quality Enamel coated Corona resistant inverter duty magnet wire. VPI with additional dip and bake.

Insulation - Class F Insulation, with B Temperature Rise

Voltage and Frequency Variation - +/- 10% as based on two voltage points of the motor being either 230 / 460 or 333 / 575

Bearings - Double sealed with Lithium grease -30 Deg to 180 Deg C

Enclosure Protection - Meets Ingress Protection Standard IP69K

Frame Construction - Paint free with all 304 Stainless steel housing and shaft. Moisture proof sealant on all machined fits and shielded Viton type double lip seal . Four condensation plugs on each end shield for mounting flexibility.

Conduit Box - The round welded terminal box design comes completely encapsulated and offers two points of entry for easy access to the terminals. All while eliminating points where contaminants can build up, and maintaining the motors IP69K rating.

Inverter Duty - Suitable for Inverter Duty applications, at all voltages for speed ranges of 10:1 constant torque and 20:1 variable torque.

Nameplate - Permanently etched to stainless steel housing

Warranty - 18 Months from the date of manufacture

PREMIUM DESIGN B NEMA 12-12

304 GRADE STAINLESS STEEL TENV TOTALLY ENCLOSED
NON-VENTILTED & TEFC TOTALLY ENCLOSED FAN COOLED



HP	RPM	VOLTS	FRAME	CAT NO.	NOM EFF.	F.L. AMPS	CODE	WT (Lbs)	DE BRG	ODE BRG	"L" Dimension (mm)
0.25	3600	230/460	63	MQS-6312	73	1.06/.53	K	17.6	6202	6202	242
	3600	575	63	MPS-6312	73	0.424	K	17.6	6202	6202	242
	1800	230/460	63	MQS-6324	75	1.06/.53	K	17.6	6202	6202	242
	1800	575	63	MPS-6324	75	0.424	K	17.6	6202	6202	242
	1800	230/460	63	MQS-6324NVB14	75	1.06/.53	K	17.6	6202	6202	241
	1200	230/460	71	MQS-7116	63	1.32/0.66	K	20.9	6203	6203	250
	1200	575	71	MPS-7116	63	0.53	K	20.9	6203	6203	250
0.33	3600	230/460	63	MQS-6322	74	1.14/.57	K	17.6	6202	6202	242
	3600	575	63	MPS-6322	74	0.456	K	17.6	6202	6202	242
	1800	230/460	71	MQS-7114	77	1.14/.57	K	18.7	6203	6203	311
	1800	575	71	MPS-7114	77	0.456	K	18.7	6203	6203	311
	1200	230/460	71	MQS-7126	67	1.44/.72	K	25.3	6203	6203	311
	1200	575	71	MPS-7126	67	0.576	K	25.3	6203	6203	311
0.5	3600	230/460	71	MQS-7112	80	1.55/.78	K	25.3	6203	6203	311
	3600	575	71	MPS-7112	80	0.62	K	25.3	6203	6203	311
	1800	230/460	71	MQS-7124	78	1.62/.81	K	23.1	6203	6203	250
	1800	230/460	71	MQS-7124NVB14	78	1.62/.81	K	23.1	6203	6203	278
	1800	575	71	MPS-7124	78	0.648	K	23.1	6203	6203	250
	1800	575	71	MPS-7124NVB14	78	0.648	K	23.1	6203	6203	278
	1200	230/460	80	MQS-8016	77	1.75/.88	K	38.5	6204	6204	325
	1200	575	80	MPS-8016	77	0.7	K	38.5	6204	6204	325
0.75	3600	230/460	71	MQS-7122	80	2.075/1.04	K	28.6	6203	6203	311
	3600	575	71	MPS-7122	80	0.83	K	28.6	6203	6203	311
	1800	230/460	80	MQS-8014	79	2.24/1.12	K	38.5	6204	6204	325
	1800	230/460	80	MQS-8014NVB14	79	2.24/1.12	K	38.5	6204	6204	322
	1800	575	80	MPS-8014	79	0.896	K	38.5	6204	6204	325
	1800	575	80	MPS-8014NVB14	79	0.896	K	38.5	6204	6204	322
	1800	575	80	MPS-8014NVB14	79	0.896	K	38.5	6204	6204	322
1	3600	230/460	80	MQS-8012-S3	81	2.68/1.34	K	34.1	6204	6204	322
	3600	575	80	MPS-8012-S3	81	1.072	K	34.1	6204	6204	322
	1800	230/460	80	MQS-8024-S3	85.5	2.84/1.42	K	44	6204	6204	322
	1800	575	80	MPS-8024-S3	85.5	1.136	K	44	6204	6204	322
	1800	230/460	80	MQS-8024S3NVB14	85.5	2.84/1.42	K	44	6204	6204	322
	1800	230/460	80	MQS-8024S3NVB34	85.5	2.84/1.42	K	44	6204	6204	322
	1800	575	80	MPS-8024S3NVB14	85.5	1.136	K	44	6204	6204	322
	1200	230/460	90	MQS-90S6FC-S3	82.5	4.2/2.1	K	44	6205	6205	369
	1200	575	80	MPS-90S6FC-S3	82.5	1.68	K	44	6205	6205	369



PREMIUM DESIGN B NEMA 12-12

304 GRADE STAINLESS STEEL TENV TOTALLY ENCLOSED
NON-VENTILATED & TEFC TOTALLY ENCLOSED FAN COOLED

MaxMotion

Applications:

A versatile motor design that can be base mounted or flange mounted to equipment operating in wet and severe conditions, and where wash down duty and corrosive elements are found such as in the food processing, bottling, dairy, pharmaceutical, and chemical processing industries.



Features:

Design - IEC Design N with NEMA Design B torque Curves

Agency Listings and Standard - NEMA, IEEE, CSA, CSAus, CE, NRCan

Service Factor - 1.15 @ 60Hz and 1.0 @ 50Hz without derating power

Electrical Supply - At 60Hz : 230/460v Dual Rated & Plated for 50Hz : 190/380-415v

Windings - Highest quality Enamel coated Corona resistant inverter duty magnet wire. VPI with additional dip and bake.

Insulation - Class F Insulation, with B Temperature Rise

Voltage and Frequency Variation - +/- 10% as based on two voltage points of the motor being either 230 / 460 or 333 / 575

Bearings - Double sealed with Lithium grease -30 Deg to 180 Deg C

Enclosure Protection - Meets Ingress Protection Standard IP69K

Frame Construction - Paint free with all 304 Stainless steel housing and shaft. Moisture proof sealant on all machined fits and shielded Viton type double lip seal . Four condensation plugs on each end shield for mounting flexibility.

Conduit Box - The round welded terminal box design comes completely encapsulated and offers two points of entry for easy access to the terminals. All while eliminating points where contaminants can build up, and maintaining the motors IP69K rating.

Inverter Duty - Suitable for Inverter Duty applications, at all voltages for speed ranges of 10:1 constant torque and 20:1 variable torque.

Installation - Horizontal Operation if Vertical operation is required, please contact factory.

Nameplate - Permanently etched to stainless steel housing

Warranty - 18 Months from the date of manufacture

